

# Granita Freezers

## Model G102, G103, G102F and G103F

Dispense frozen drinks quickly and easily with these compact 2 bowl and 3 bowl countertop freezers. Ideal for making Frozen Granita Drinks, Cocktails, Coffees, Teas, Iced Cappuccino, Slush and Smoothies. May also be operated as a chilled beverage dispenser. Models G102F and G103F incorporate a larger compressor, and freeze down up to 30% faster.

## Special Features

### Removable Bowls

Individual large 3 gallon clear bowls are easy to remove for cleaning and are designed to be a visual merchandiser. Colorful top merchandisers are front and back lit.

### Viscosity Control

Independent, adjustable viscosity controls for each bowl.

### Self-closing Handle

Spring operated dispensing handle closes automatically. Ideal for self serve applications. The handle and hopper are both available with an optional locking mechanism for added security.

### Beater Assembly

Single piece beater assembly with scraper designed for lasting durability.

### Chilled Mode

Freezer can also be used as a chilled beverage dispenser.

### Optional Auto Fill

Optional auto fill system to blend syrup and water to the proper ratio for you...no mixing necessary.

### Optional Timer

Optional defrost timer can be preset to go into chilled mode during non business hours.



Model G102  
G102F



Model G103  
G103F

BATCH  
 FROZEN COCKTAIL  
 SLUSH  
 SHAKE  
 YOGURT  
 SOFT SERVE

# ELECTRO FREEZE®

## Plumbing & Electrical Connections

8 INCH CLEARANCE REQUIRED  
ON REAR AND SIDES

8 INCH CLEARANCE REQUIRED  
ON REAR AND SIDES

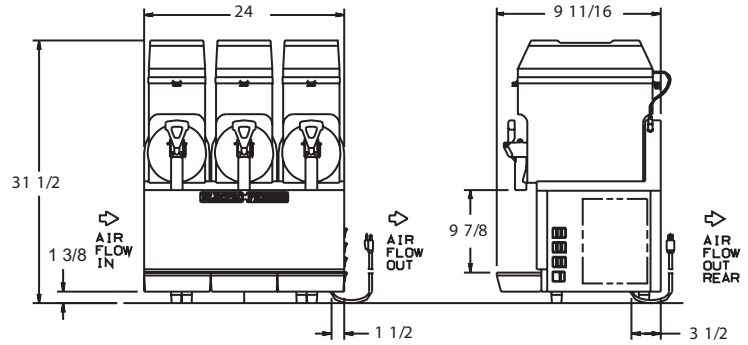
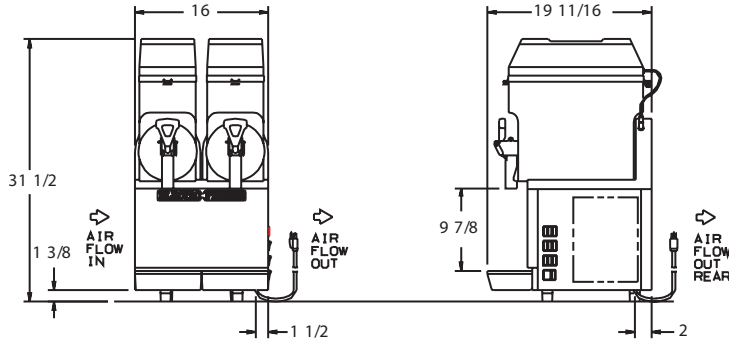

**Model G102 G102F**

**Model G103 G103F**

### SPECIFICATIONS

All specifications subject to change without notice.

Model	Capacity (Quarts)	Depth	Width	Height	Shipping Wt.	Single Phase	Amps
G102	12	19-11/16" 50 CM	16" 40 CM	31-1/2" 80 CM	104 LB.	115V	9.1
G102F	12	19-11/16" 50 CM	16" 40 CM	31-1/2" 80 CM	104 LB.	115V	12.0
G103	12	19-11/16" 50 CM	24" 61 CM	31-1/2" 80 CM	145 LB.	115V	13.7
G103F	12	19-11/16" 50 CM	24" 61 CM	31-1/2" 80 CM	145 LB.	115V	16.0

Refrigerant: 404a

**Authorized Distributor**

**division of H.C. DUKE & SON, INC.**

2116 - 8th Avenue • East Moline, Illinois 61244  
 Phone (309) 755-4553 • (800)755-4545  
 Fax (309) 755-9858

E-mail: sales@electrofreeze.com • www.electrofreeze.com

Certified and/or listed by:



\*Listed by Underwriters Laboratories under Canadian National Standard C22.2 No. 120-M91

Also CLASSIFIED in accordance with NSF #6